

Spring Cylinder Rotary Actuator



Rotary Actuator

Spring Cylinder Rotary Actuators

High torque and pneumatic stiffness combine together in the Mascot "Spring cylinder rotary actuator" These characteristics are designed into a lightweight, rugged and compact assembly, making the Mascot rotary actuator the first choice for quarter turn applications. The Mascot rotary actuator is created for operating the DC Series high performance butterfly valve, the VB Series or other applications requiring precision in rotary motion. For throttling applications, Mascot pneumatic and electro-pneumatic positioners are available.

The actuator, Mascot positioner, and cylinder uses a rocking piston for direct conversion of linear motion to rotary motion. The rocking piston assembly along with a splined shaft and lever eliminates any lost motion.

(*See Tables I and II for limitations on certain sizes.)

Figure 1: Spring cylinder rotary actuators

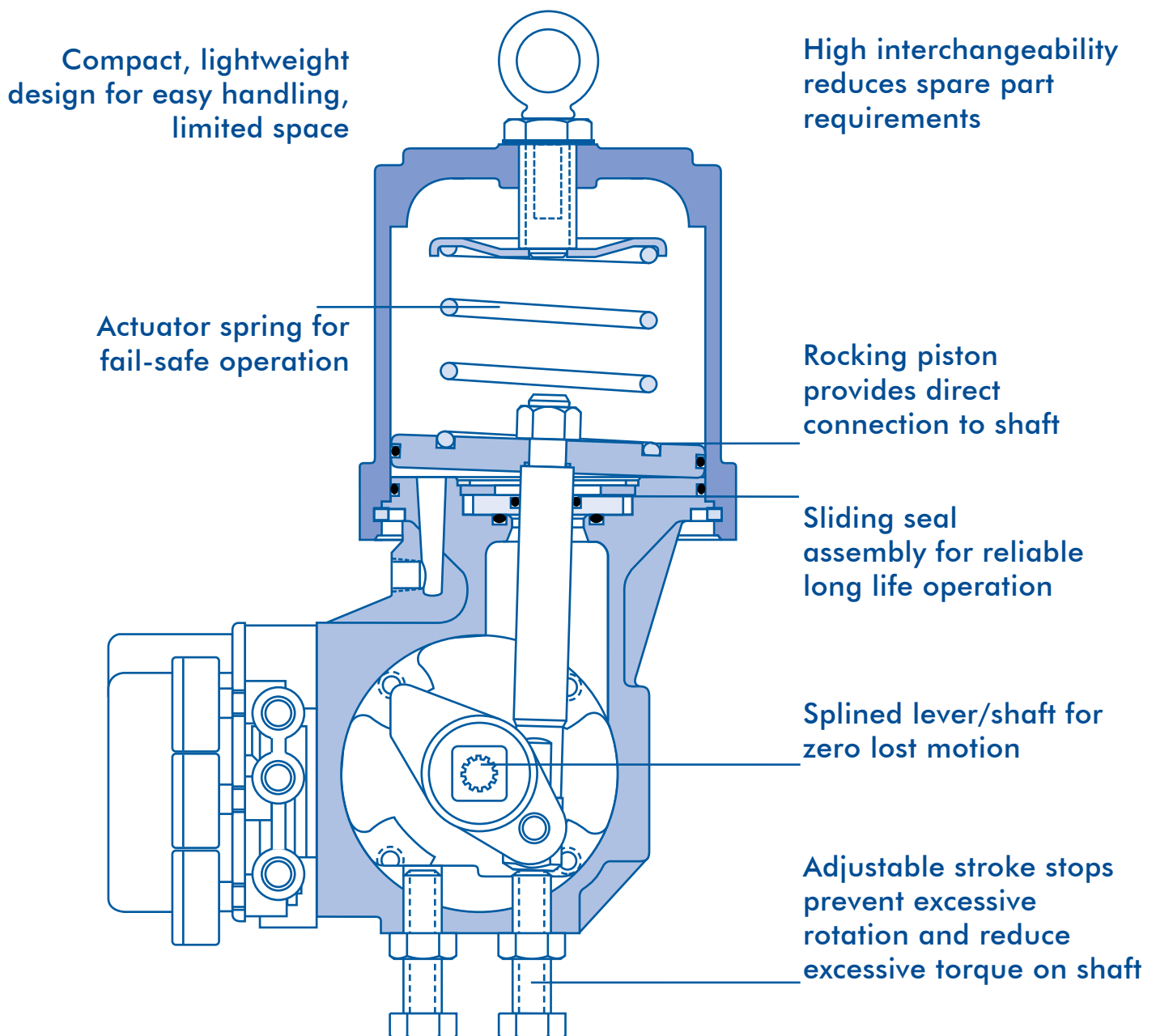

Rotary Actuator

Features and Advantages

Salient features and advantages of the Mascot rotary Spring cylinder actuator are :

Salient features	Advantages
Upto 150 psi air supply	Higher torques achieved Stiff piston positioning Higher P limits on valve possible
Rocking piston	Direct connection to shaft Zero loss motion between actuator and valve Fewer parts involved
Spined shaft and lever	Zero lost motion possible
Rugged, Compact and Light weight	Installs in limited space applications Easy maintenance Meets seismic requirements
Low friction bearings	Provide millions of cycles with minimal wear Combined with direct linkage, provides very low hysteresis
Field Reversible	No extra parts needed Fast easy field reversing possible No change of spring action needed
Fail-safe spring	Without pressure assistance, moves the actuator to failure position
Air-purged, fully enclosed transfer case	Safe operation Four monitoring positions without reducing, changing or adding parts External position indicator present Prevents corrosion of linkage
Stroke stops	Allow both ends of stroke to be adjusted

Mascot rotary spring cylinder actuator - Capitalising on established features of other Mascot actuators:

Dynamic, Interchangeability	Conveniently uses identical parts in differing rotary actuator sizes Uses many Mascot linear actuator parts Minimizes stocking of spares Minimal inventory costs
Spool-type four-way Positioner	Ease of calibration and maintenance due to fewer parts High performance modulating positioner control

Mascot's rotary spring cylinder actuator features high torques, positioning stiffness and easy maintenance to produce a high-performance rotary actuator that excels in maintenance-free throttling and on/off control applications.

Rotary Actuator

Stiffness

A 25 square inch cylinder actuator (typical for a 2" valve) with a supply air pressure of 100 psi, the spring rate would be nearly 10,000 pounds per inch near the seat. As the volume under the piston becomes smaller, the stiffness factor becomes larger in a Mascot spring cylinder rotary actuator. The resulting higher actuator stiffness in cylinder actuators is that without position fluctuations caused by flow fluctuations, rotary valves can be operated in the flow-to-close orientation.

Spring rate for a diaphragm actuator remains the same, irrespective of diaphragm position. An equivalent diaphragm actuator (46 square-inches) on the same valve with a 3-15 psi signal has a spring rate of less than 1000 pound per inch. Sudden changes in dynamic force can cause valve to slam shut when a rotary valve with a diaphragm actuator is operated near its closed position.

As opposed to this, the stiffness of Mascot spring cylinder rotary actuators increases as the closing member approaches the sitting surface. Mascot rotary actuators and rotary valves are well operated with the valve shaft downstream or upstream. Please see Mascot's Sizing & Selection Manual, Section 16, Rotary Actuator Sizing, for more information.

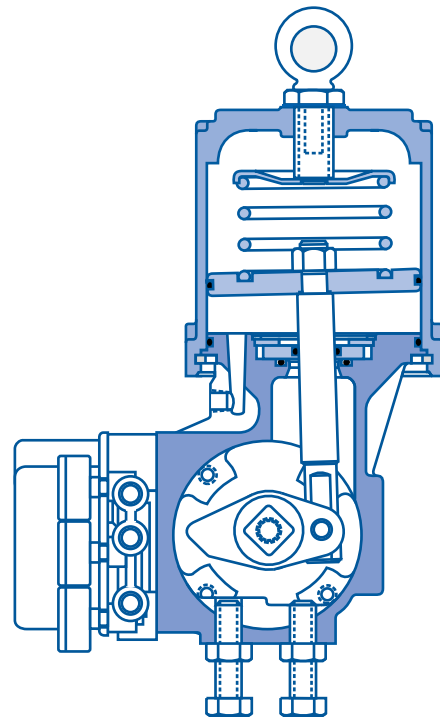

Figure 2: Actuator at Mid-stroke

Control valves are mostly used by the process control industry for regulating constantly fluctuating flows. As the dynamic forces of a flow increase or decrease, it is mandatory to have a control valve that remains in the same position as dictated by the controller. Thus making the valve is dependent upon the actuator stiffness for minimizing these position fluctuations.

Actuator stiffness can be defined as the ability of the actuator to withstand suddenly changing dynamic fluid forces acting on the valve trim.

Since supply air pressure is delivered to both sides of the piston in the cylinder, the stiffness of the Mascot spring cylinder rotary actuator is significantly greater than that of a diaphragm actuator.

The stiffness (spring rate) is equal to the expression:

$$K = \frac{kPA^2}{v}$$

- Where:
- K = spring rate
 - k = ratio of specific heat
 - P = supply pressure
 - A² = piston area (in ²)
 - v = cylinder volume under piston

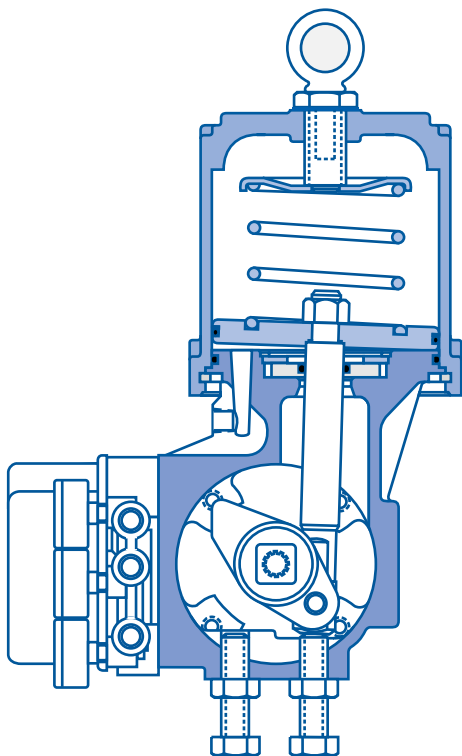

Figure 3: Actuator with High Stiffness/Spring Rate

Rotary Actuator

Performance

Torque Producing Capability

Substantially high torque is produced by Mascot spring cylinder rotary actuators than the diaphragm actuators as the cylinder operates with supply pressures upto 150 psi. 40 - 60 psi is the limit for throttling diaphragm actuators, thus decreasing their torque producing capabilities to produce higher torque. Higher actuator air supply, coupled with high-pressure air on both sides of the actuator piston, provide exceptional stiffness for precise throttling control. To permit the valve to throttle near the seal and to control high pressure drops, the stiffness of Mascot rotary actuator is sufficient.

Cam Characterizable Operation

Mascot's standard Valve positioner, is provided with a reversible cam that characterizes Disk control valve CV to either modified equal percent or linear performance. The same cam enhances the V Notch ball valve's inherent equal percent characteristic. A second rotary cam is also available. This optional cam gives V Notch ball valves a linear relationship of rotation with respect to the controller signal. It is reversible for use in air-to-open, air-to-close or fail/open applications and in this mode is also linear.

Speed and Sensitivity

Fast stroking speeds are produced with the combination of High air-handling capacity of the positioner, with relatively low cylinder volumes. High operating speed is achieved with virtually no overshoot when approaching the final disc or ball position. At the same time, static sensitivity of the unit is excellent. For example, as little as 0.017 psi is required to rotate the shaft 0.01 degrees (the minimum detectable movement in the tests conducted) on a size 25 actuator. To reverse the shaft motion, a signal change of only 0.02 psi is required.

Frequency Response

The Mascot cylinder rotary actuator frequency response is extremely high - generally an order of magnitude better than comparable diaphragm actuator units. Such response is achieved through a double-acting configuration that uses pressure on both sides of the piston.

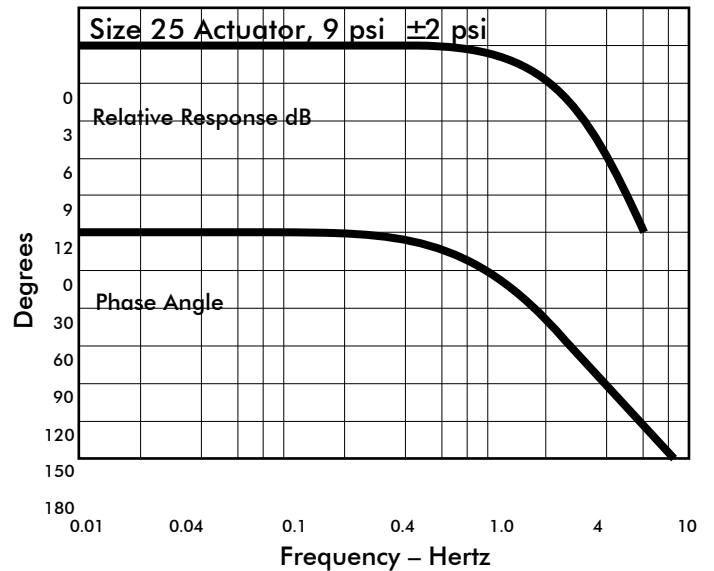

Figure 4: Frequency Response

Hysteresis and Repeatability

Any actuator should have ability to respond to signal changes from the controller and to give uniform response unaffected by decreasing or increasing pressures. Tests prove that on a full scale, hysteresis and repeatability of the spring cylinder rotary actuator, with valve positioner are less than 0.7 percent. (See Table VII: Valve Positioner Performance on page 10.)

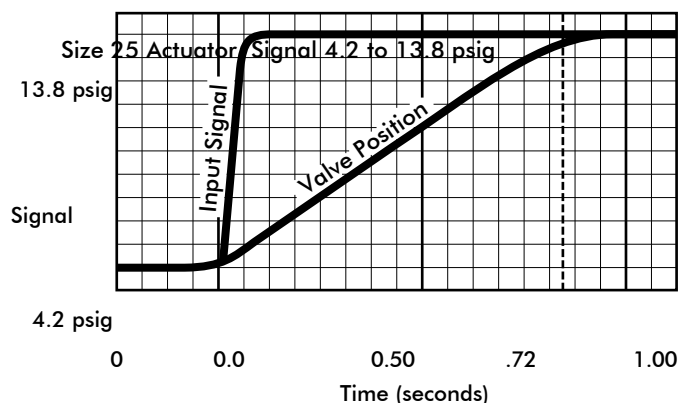

Figure 5: Step Test

Rotary Actuator

Output torque

Table I: Net Torque Output of Actuators at Various Supply Pressures, (in.-lb.)

Actuator Size	Supply Pressure	Degrees from Fail Position on Air Supply Loss									
		0	10	20	30	40	50	60	70	80	90
STD 25 with STD Spring	150	3013	3399	3700	3907	4000	3970	3811	3514	3084	2532
	140	3808	3165	3444	3631	3714	3685	3531	3253	2854	2339
	120	2397	2695	2928	3080	3145	3110	2972	2731	2390	1962
	100	1986	2228	2412	2530	2573	2535	2414	2211	1928	1577
	80	1574	1759	1896	1979	2002	1961	1856	1688	1463	1191
	60	1163	1290	1381	1428	1430	1386	1298	1167	1001	806
	Spring Torque	72	115	167	225	284	338	379	399	391	349
STD 25 with HD Spring	150	2647	2973	3223	3386	3448	3403	3246	2976	2600	2124
	140	2441	2738	2964	3110	3162	3115	2966	2716	2368	1931
	120	2030	2270	2450	2558	2590	2542	2409	2195	1905	1552
	100	1618	1802	1934	2009	2020	1967	1850	1673	1441	1167
	80	1206	1333	1418	1457	1448	1392	1292	1151	978	781
	60	795	865	902	907	877	818	733	630	515	396
	Spring Torque	440	542	647	749	839	908	945	937	878	758
STD 50 with STD Spring	150	10701	11981	13015	13751	14134	14089	13575	12568	11043	9035
	140	9970	11157	12114	12798	13136	13083	12596	11653	10232	8365
	120	8516	9513	10318	10874	11141	11075	10649	9826	8615	7053
	100	7059	7873	8515	8953	9153	9073	8693	7999	6995	5712
	80	5602	6227	6716	7033	7156	7062	6736	6174	5372	4373
	60	4147	4586	4913	5114	5166	5058	4784	4347	3755	3034
	Spring Torque	222	343	489	651	816	966	1081	1134	1107	983
STD 50 with HD Spring	150	9774	10898	11781	12380	12651	12533	12000	11036	9648	7850
	140	9044	10074	10880	11425	11652	11527	11021	10122	8837	7183
	120	7591	8430	9083	9502	9657	9519	9073	8300	7216	5865
	100	6133	6790	7281	7585	7668	7516	7117	6473	5597	4527
	80	4678	5148	5481	5660	5671	5508	5163	4646	3974	3186
	60	3223	3505	3681	3741	3680	3501	3209	2821	2356	1846
	Spring Torque	1148	1428	1726	2026	2304	2529	2662	2667	2511	2167
STD 100 with STD Spring	150	26194	29415	32022	33847	34730	34559	33234	30711	26943	22035
	140	24385	27397	29784	31459	32253	32069	30831	28446	26936	20378
	120	20805	23329	25330	26685	27303	27104	25983	23921	20932	17119
	100	17226	19271	20859	21914	22368	22119	21134	19394	16920	13808
	80	13640	15200	16399	17153	17413	17133	16296	14878	12915	10485
	60	10055	11139	11929	12391	12472	12159	11447	10350	8901	7167
	Spring Torque	704	1049	1461	1913	2370	2783	3088	3225	3135	2775
STD 100 with Dual Springs	150	24678	27231	29008	29925	29917	28969	27058	24266	20699	16483
	140	22881	25195	26771	27539	27459	26475	24632	22001	18691	14832
	120	19304	21127	22317	22784	22507	21490	19782	17472	14680	11563
	100	15713	17070	17847	18012	17567	16518	14946	12956	10674	8245
	80	12130	12999	13385	13248	12612	11538	10101	8432	6662	4927
	60	8545	8939	8921	8483	7673	6558	5257	3910	2662	1611
	Spring Torque	2217	3256	4485	5831	7185	8405	9299	9691	9407	8316
STD 200 with STD Spring	80*	27695	31132	33903	35838	36820	36663	35280	32620	28633	23416
	70	24156	27119	29480	31134	31916	31730	30501	28139	25670	20206
	60	20595	23091	25069	26406	27014	26813	25699	24656	20697	16926
	50	17051	19072	20643	21696	22126	21876	20897	19173	16724	13646
	Spring Torque	704	1049	1461	1913	2370	2783	3088	3225	3135	2775
STD 200 with Dual Springs	80*	26192	28930	30894	31940	32005	31052	29104	26177	22393	17887
	70	22636	24918	26467	27214	27122	26136	24302	21693	18420	14650
	60	19094	20889	22056	22505	22217	21198	19499	17208	14445	11370
	50	15538	16872	17629	17779	17326	16275	14709	12735	10478	8083
	Spring Torque	2217	3256	4485	5831	7185	8405	9299	9691	9407	8316

NOTE: For air-to-open/fail-closed actuators the 0 degree position shown above corresponds to the disc or ball being seated. For air-to-close/fail-open actuators the 90 degree position shown above corresponds to the disc or ball being seated. * Size 200 actuator limited to 80 psi air supply - pressure

Rotary Actuator

Specifications

Table II: Rotary Actuator Data

Actuator Size (sq.in.)	Stroke (inches)	*Actuator Moment Arm (inches)	Max Air Supply (psi)	Spring Design	Spring Rate (lb./in.)	Upper Cylinder Area (sq.in.)	Lower Cylinder Area (sq.in.)	Shipping Weight**
25	1.88	0.94	150	STD HD (Cap)	180 222	23.76	23.07	30
50	3.25	1.63	150	STD HD (Cap)	164 235	47.17	46.07	60
100	4.00	2.00	150	STD DUAL	300 885	95.03	93.26	160
200	4.00	2.00	80	STD DUAL	300 885	188.69	186.92	265

* Valve in closed position

** Estimated, including Valve Positioner

Table III: Actuator Specifications

Type	Cylinder with positive spring action
Sizes	25, 50, 100 and 200 sq. in.
Spring Designs	Single (std.), heavy-duty, dual
Action	Field reversible: Air-to-open, Air-to-close
Operating pressure	Up to 150 psi**
Temperature range	-40°F to 350°F*

* Ambient temperatures greater than 180°F require Viton O-rings. Ambient temperatures below -40°F require fluorosilicone O-rings.

** See Table II for limitations on certain actuators.

Table V: Materials of Construction

Yoke	Ductile iron
Transfer case	Anodized aluminum
Splined lever arm	Ductile iron
Stem	416 stainless steel
Bearings	Filament wound fiberglass with Teflon liner
Sliding seal	Delrin 100, aluminum
Retaining ring	Cadmium plated steel
Piston	Anodized aluminum
Cylinder	Anodized aluminum
O-ring	Buna N (std.)
Actuator spring	Coated steel (rust proof)
Spring button	Painted steel or cadmium plated

**Table IV:
Stroking Speeds with Positioner***

Actuator Size	Time in Seconds for 90° Rotation		Actuator Stroke (inches)
	1/4" Tubing (standard)	3/8" Tubing (optional)	
25 (std)	1.0	1.0	1.88
50 (std)	3.5	3.5	3.25
100 (std)	9.5	9.0	4.00

* Valve positioner stroking valve to fail position. Consult factory for speeds faster than those shown above.

Ordering Information

When ordering individual rotary actuators, the following information must be provided:

1. Operating conditions, throttling or on/off.
2. Maximum air supply pressure.
3. Valve rotation in degrees.
4. Actuator torque required at both ends of rotation.
5. Positioner and input signal range, if needed.
6. Stroking time requirements, if critical.

Rotary Actuator

Valve Positioners

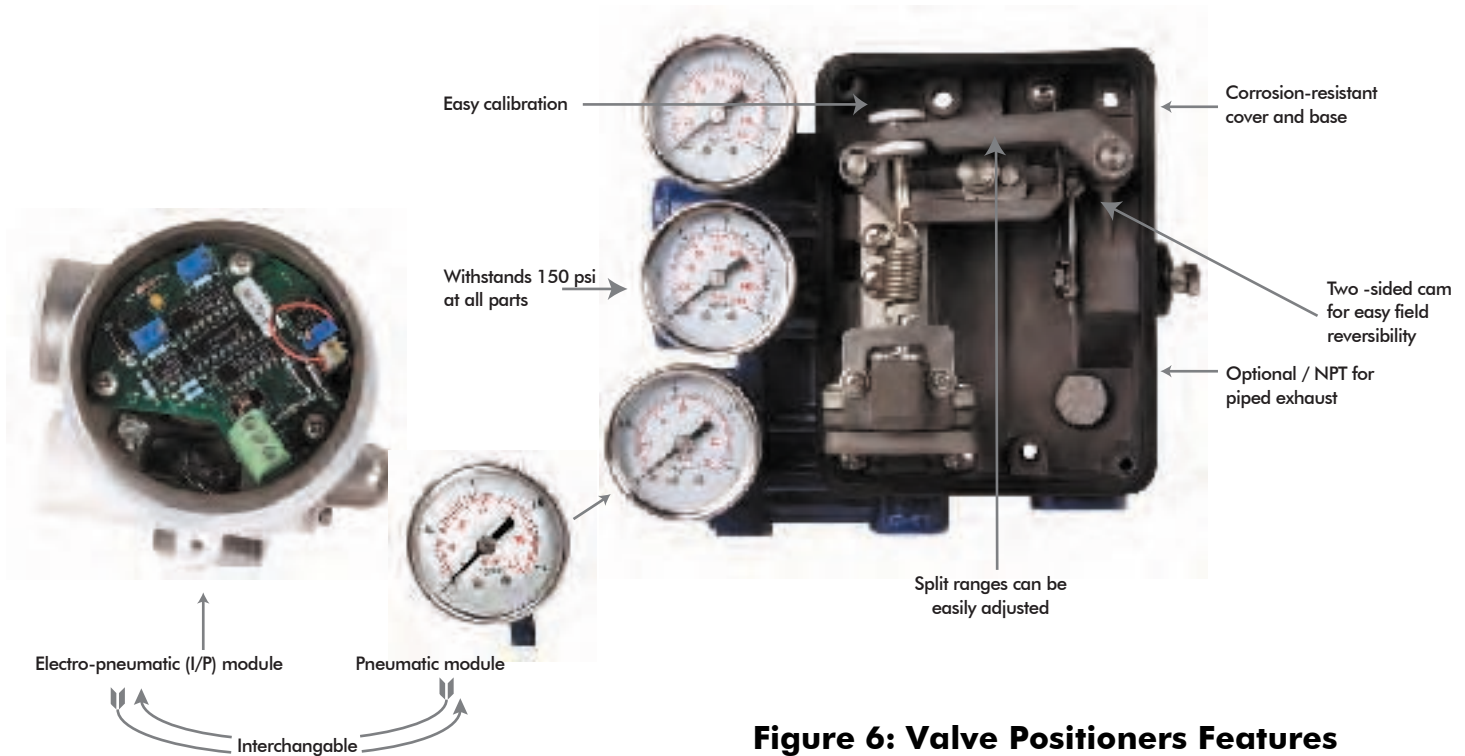

Figure 6: Valve Positioners Features

Valve positioners are primarily utilized by Mascot. A pneumatic module for air control signals, or an electro-pneumatic (I/P) module for milliamp electrical control signals is offered with Mascot valve positioner. Valve positioners are single or double-acting, force-balanced instruments that provide fast, sensitive and accurate positioning of cylinder and diaphragm actuators. These positioners being compact, field reversible, are designed for high performance and are reliable because of the rugged built.

Features

- **P/P or I/P Signal Convertible** – Easy accomplishment of field conversion from one control signal to another by replacing one module with another
- **Corrosion Resistant** – Epoxy powder painted on cover and base assembly and continuously purged from the inside with instrument air making corrosion resistant internal section. Internal working parts are constructed from 300 series stainless steel, anodized aluminum or Buna-N.
- **Shock and Vibration Resistant** – the make and design of valve positioners is such that they have high natural frequency coupled with pneumatic damping. It is unaffected by vibration, acceleration up to 2 G's, and frequencies to 500 Hz.
- **For Single or Double-acting Actuators** – The valve positioner is versatile usable with either single or double acting actuators.
- **Standard Mounting** – Valve positioners use the standard mounting. By changing the cams and follower arms, the same positioner can be used on both linear and rotary actuators. This results in fewer required spare parts.

- **Easily Field Reversed** – A reversal of action in the field is achieved by simply turning the cam over, reversing the anti-backlash spring and changing the output tubing.
- **Insensitive to Mounting Position** – Positioners can be mounted in any orientation.
- **Simple Calibration** – Easy calibration as there is minimal interaction between zero and span. For protection and to discourage tampering, positioner adjustments are totally enclosed.
- **Split-Range Service** – Standard signal ranges are 4 - 20 mA for the electro-pneumatic (I/P) module and 3-15 psi (0-1 Bar) for the pneumatic (P/P) model. Optional ranges are 10-50 mA and 6-30 psi (0.4-2.1 Bar), respectively. All models can be calibrated for a 2 or 3-way split range.
- **Simplified Maintenance** – Ease in maintenance because of positioners simplicity, modular design and a few parts.
- **Regulator not needed** – Designed to withstand 150 psi (10.3 bar) at all parts, the valve positioners are insensitive to supply pressure fluctuations.
- **Low Air Consumption** – Steady state air consumption is .25 SCFM @ 60 psi (4.1 Bar) supply.
- **Changeable Flow Characteristics** – Easily changed cam provides characterized flow feedback.
- **High Air Flow Gain Model** – Standard on 200 square inch actuators and above, optional on others.
- **Output Gauge Helps Monitor Unit:** – Permits easy verification of transducer and positioner calibration as it indicates transducer output to the positioner.

Rotary Actuator

Valve Positioner Operation

Figure 4 shows a valve positioner. The valve positioner is a force-balanced instrument, with pneumatic module installed on a double-acting actuator for air to open action. Positioning is based on a balance of two forces; one proportional to the instrument signal and the other proportional to the stem position.

A downward force is activated as the signal pressure acts upon the diaphragms in the instrument signal capsule, through the follower arm and cam, the motion of the actuator stem is transmitted to the top end of the feedback spring resulting in the varying of tension in feedback spring as stem position changes.

The system will be in equilibrium and stem will be in the position called for by the instrument signal when these opposing forces balance exactly. The balance will move up or down and by means of the spool valve, will change the output pressures and flow rate if these opposing forces are not in balance. This will lead to the piston to moving until the tension on the feedback spring opposes exactly the instrument signal pressure.

The detailed sequence of positioner operations are as follows: An increase in the instrument signal forces

the instrument signal capsule and balance beam downward. This motion of the balance beam also pulls the pilot valve spool downward from its equilibrium position. This opens the pilot valve ports, supplying air to port 1 and exhausting air from port 2. This causes the actuator piston upward.

Proportionally to the valve position, to counter the force generated by the instrument signal capsule, the piston continues to stroke upwards until force in the feedback spring increases sufficiently. At this point the balance beam and spool begin to return to equilibrium position. As the valve spool ports start to close, the air flow rate to the actuator is decreased.

The feedback spring tension force will equal the force generated in the instrument signal capsule after the piston has reached the required position. The balance beam and instrument signal capsule will remain in their equilibrium positions with no air flowing to the actuator until a change in the instrument signal is made.

A proportional downward movement of the actuator piston and stem is affected by a decrease in the instrument signal which reverses the described actions.

Figure 4 : Positioner Schematic for Air-to-Open (Retract)

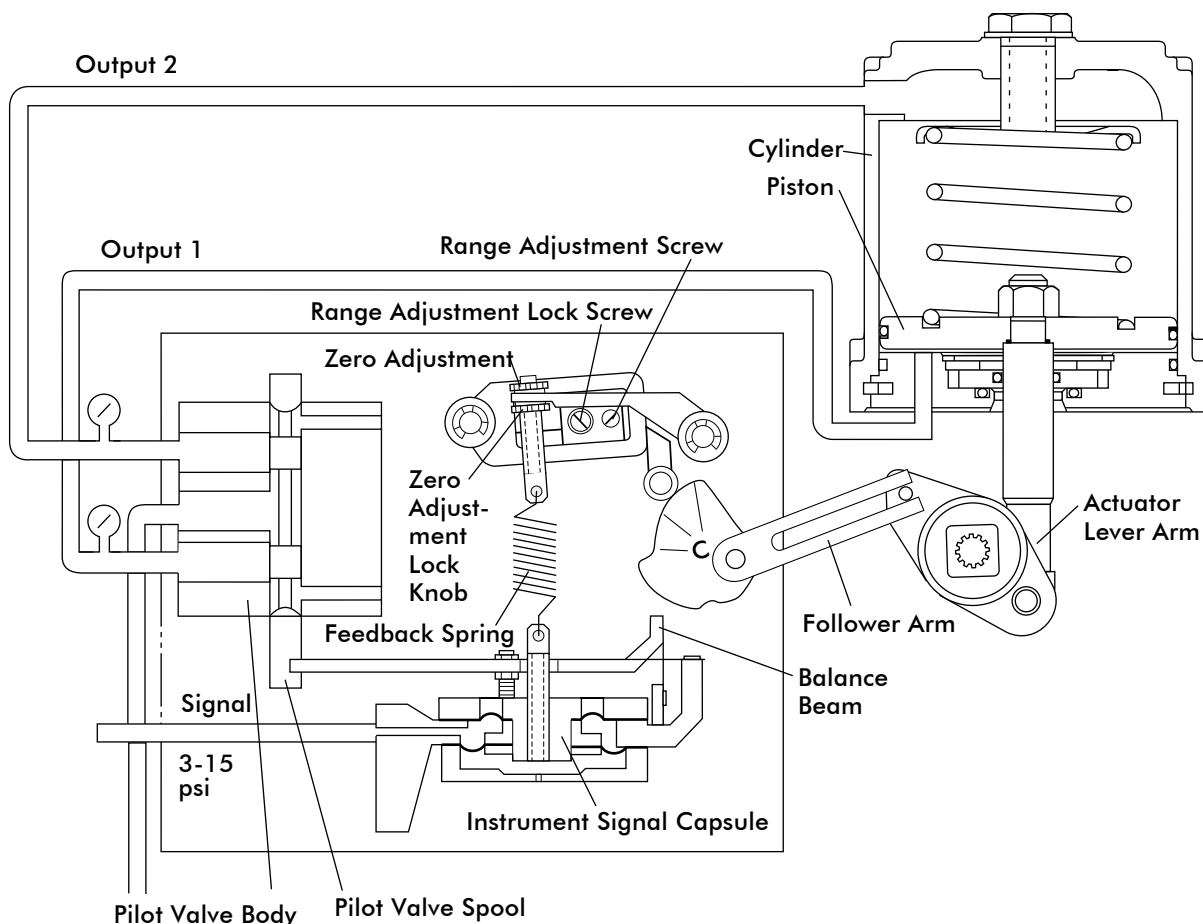

Rotary Actuator

Specifications

Table VI: Valve Positioner Specifications

Specification	Pneumatic Module	I/P Module
Input signal range:	3 -15 psi, 2 or 3-way split range; 6-30 psi, 2 or 3-way split range; 4-way split range	4-20 and 10-50 mA with 2 or 3 and 4-way split range
Supply pressure	30 psi to 150 psi	Same
Ambient temperature limits	Standard model: -20°F to +185°F Ext. temp. model: -50°F to +250°F	Standard model: -20°F to +180°F Ext. temp. model: -40°F to +180°F
Connections	Supply, instrument and output: 1/4-inch NPT; Gauges: 1/8-inch NPT	Signal: 1/2-inch NPT elect. conduit; Output: 1/4-inch NPT; Gauges: 1/8-inch NPT
Standard materials	Stainless steel, anodized aluminum, nickel-plated steel, epoxy powder-painted steel and Buna-N	Same
Loop Load	N/A	5.3 volts + 5 ohms (270 ohms at 20 mA)
Hazardous Location Approvals (FM and CSA approved)	N/A	Intrinsically safe: Class I, Division 1, Groups A, B, C, D; Class II, Groups E, F, G Explosion-proof: Class I, Division 1, Groups B, C, D; Class II, Groups E, F, G Non-incendive: Class I, Division 2, Groups A, B, C, D, F, G
Net weight	3 lbs.	5.5 lbs.

Table VII: Valve Positioner Performance*

	Pneumatic Module	IP 2000 Module
Independent Linearity - Maximum deviation from a best fit straight line	±1.0% F.S.	±1.0% F.S.
Hysteresis - Maximum position error for the same value of input when approached from opposite ends of the scale.	0.5% F.S.	0.5% F.S.
Repeatability - Maximum variation in position for the same value of input when approached from the same direction.	0.2% F.S.	0.2% F.S.
Response Level - Maximum change in input required to cause a change in valve stem position in one direction.	0.2% F.S.	0.2% F.S.
Dead Band - Maximum change in input required to cause a reversal in valve stem movement.	0.3% F.S.	0.3% F.S.
Resolution - Smallest possible change in valve stem position.	.1% F.S.	.1% F.S.
Steady State Air Consumption @ 60 psi	.25 SCFM	.31 SCFM
Supply Pressure Effect - Position change for a 10 psi supply pressure change.	.05 % F.S.	.06% F.S.
"Open-loop" Gain - Ratio of cylinder pressure unbalance to instrument pressure change with locked stem.	300:1 psi/psi @60 psi	400:1 psi/mA @60 psi
Maximum Flow Capacity @ 60 psi	11 SCFM	11 SCFM
Frequency Response - (With sinusoidal input of ±5% F.S. centered about 50% F.S.)	-6 dB Frequency Phase Angle at -6dB	.8 Hz -71.1°
Stroking Speed -	Closed to open -	2.3 in/sec.
	Open to closed -	1.3 in./sec.

*Data is based on tests of the Valve positioner mounted on a double-acting cylinder actuator having a piston area of 25 square inches with a valve stroke of 1.5 inches and 60 psi supply pressure. Instrument signal was 3-15 psi with pneumatic module and 4-20 mA with I/P module.

Rotary Actuator

Accessories

Declutchable Handwheel Actuator

It has been designed to override the actuator in case of air failure or if manual operation is desired. A special high-output worm gear develops as much torque as the standard Mascot pneumatic rotary actuator.



Manual Handwheel Actuator

(Applications requiring infrequent use but reliable operation, a high-torque, manual handwheel actuator is available.) There are three sizes to match the torque requirements of any application. For maintenance free operation, the sealed housing is made of cast iron and filled with grease.

Heavy-duty Springs

For high shutoff pressure, heavy-duty springs are available. A spring cap installed in the cylinder is used for high pressure drop applications, requiring the installation of the longer heavy-duty spring. The same spring can be used for both fail-open and fail-closed applications. Dual springs are available with 100 and 200 square-inch rotary actuators.

Solenoid Valves

To interrupt the instrument signal to the pneumatic positioner, the three-way solenoid valve is used. For on/off applications where throttling is not required, only four-way solenoid valve (without the Positioner) is used. It ensures fast, positive, two-directional action. Solenoid valves are available in both AC and DC voltages.

Position indicator (PT Series)

Position indicator is a position transmitter that exceeds the capabilities of normal limit switches by providing a continuous electrical output signal proportional to the position of the control valve. Position indicator operates with two wires on a 4 to 20 mA DC voltage, ensuring infinite resolution for safe, dependable monitoring of a control valves position to within linearity ± 1 percent. Mounted on the transfer case opposite the valve, the infinite resolution potentiometer is easily adjusted with zero and span settings for field calibration. Position indicator models may contain a potentiometer and transmitter, two or four limit switches, or a combination of a transmitter and two limit switches. (Weather and explosion-proof protection from external conditions is provided A rugged. Sudden changes)



Air Filters

An air filter is recommended for installation upstream of the positioner. It features high flow capacity and handles up to 150 psi supply air pressure. Easy access to the large drip well permits inspection and replacement of the filter cartridge, while the integral drain valve allows removal of trapped oil, moisture and other foreign material. Regulators are usually not required with Mascot actuators and positioners.

Rotary Actuator

Dimensions

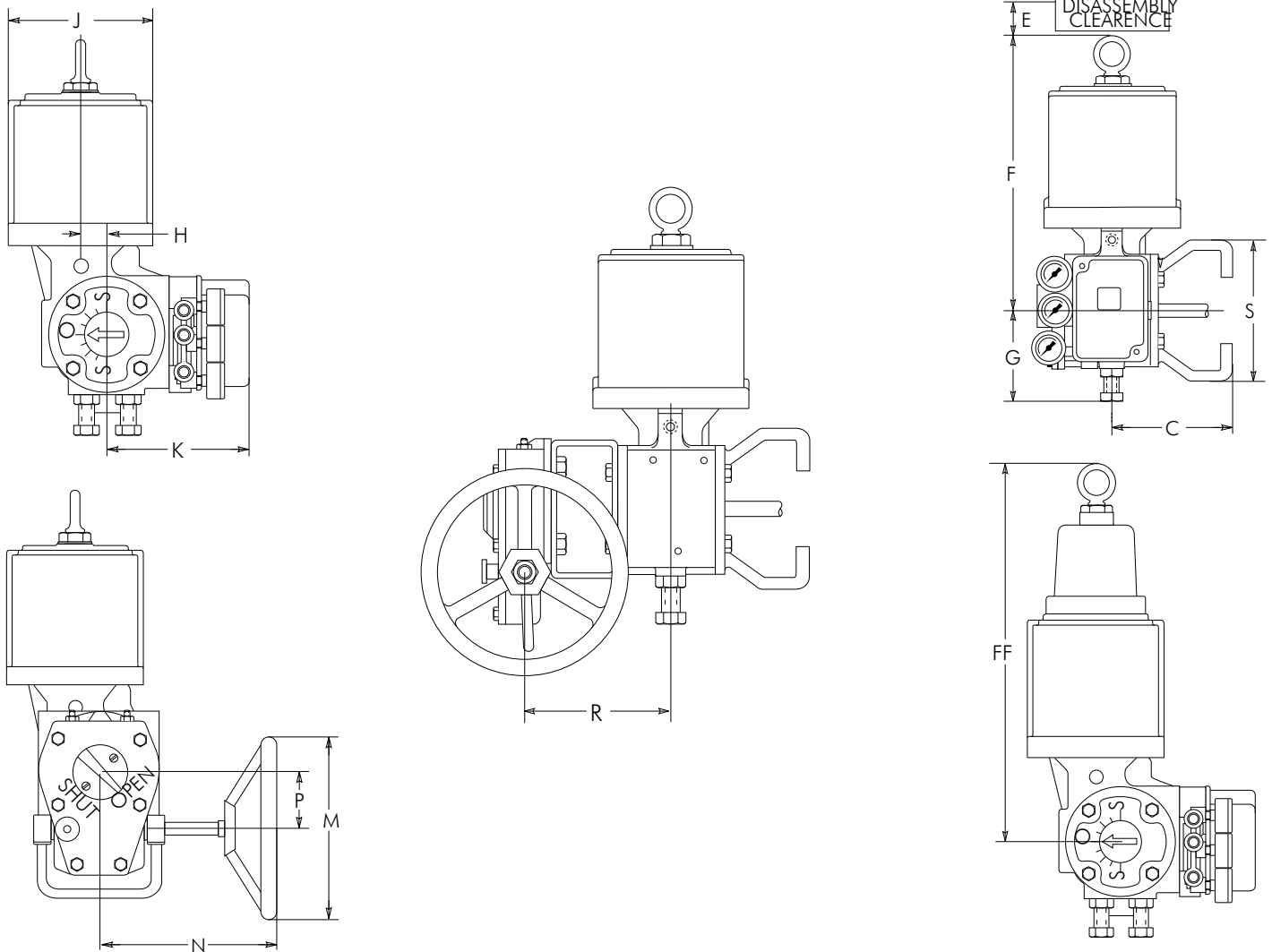

Table VIII: Rotary Actuator Dimensions (inches/mm)

Size (in.)	C*		E		F		FF		G		H		J		K		M		N		P		R		S**		Press. Conn.
	(in.)	(mm)	(in.)	(mm)	(in.)	(mm)	(in.)	(mm)	(in.)	(mm)	(in.)	(mm)	(in.)	(mm)	(in.)	(mm)	(in.)	(mm)	(in.)	(mm)	(in.)	(mm)	(in.)	(mm)	(in.)	(mm)	
25	6.7	171	6.0	152	13.1	332	16.5	420	5.6	142	1.1	29	6.5	165	6.5	166	10.0	254	9.8	248	2.6	67	6.9	176	6.8	171	1/4 NPT
50	6.7	171	8.0	203	17.2	437	23.5	598	6.7	170	2.0	50	9.1	232	7.4	188	12.0	305	10.3	260	3.4	86	9.1	230	6.8	171	1/4 NPT
100	6.7	171	11.0	279	22.9	583	N/A	N/A	9.1	230	2.4	61	12.5	318	8.5	215	18.0	457	12.8	324	5.4	137	10.4	263	6.8	171	3/4 NPT
200	6.7	171	11.0	279	23.6	599	N/A	N/A	9.1	230	2.4	61	17.5	445	8.5	215	18.0	457	12.8	324	5.4	137	10.4	263	6.8	171	3/4 NPT

*7.8/198 on size 100 and 200 actuators, 16-inch and larger valves.

**7.9/202 on size 50 actuators and 8, 10-inch valves; 9.4/238 on size 100, 200 actuators and 8,10,12-inch valves; 11.3/286 on size 100, 200 actuators and 16-inch and larger valves.

NOTE: Size 100 and 200 actuators do not include lifting rings.